



GfG Instrumentation
Worldwide Supplier of Gas Detection Solutions

CC 0238

Operation Manual



Content

	Page
For your Safety	3
General Description	3
Detection Principle	4
Operational Notes	4
Design	5
Mounting Position of CC 0238	6
Mounting	6
Installation of Electrical Connections	7
Putting into Operation	7
Check of Electrical Zeropoint	8
Check of Sensitivity	8
Signal Transmission	9
Service	9
Maintenance and Inspection	10
Functional Restrictions depending on Oxygen Concentration	10
Display Irritation due to Sensor Poisons	10
Trouble Shooting	11
Spare Parts	11
Accessories	11
Connection Diagram CC 0238	11
Technical Data	12
Index	13

For your Safety

Like any piece of complex equipment, the GfG CC 0238 will do the job designed to do only, if it is used and serviced in accordance with the manufacturer's instructions. This manual must be carefully read by all individuals who have or will have the responsibility for using and servicing this product.

The warranties made by GfG with respect to the product are voided, if the product is not used and serviced in accordance with the instructions in this manual. They are also voided, if function or parameter settings are effected without GfG's authorization. The above does not alter statements regarding GfG's warranties and conditions of sale and delivery.

General Description

A fixed gas monitoring system consists of a transmitter (MWG) and a control module (GMA), which are connected by means of a transmitter cable. The transmitter converts the gas concentration into an electrical signal, which is sent to the GMA for evaluation.

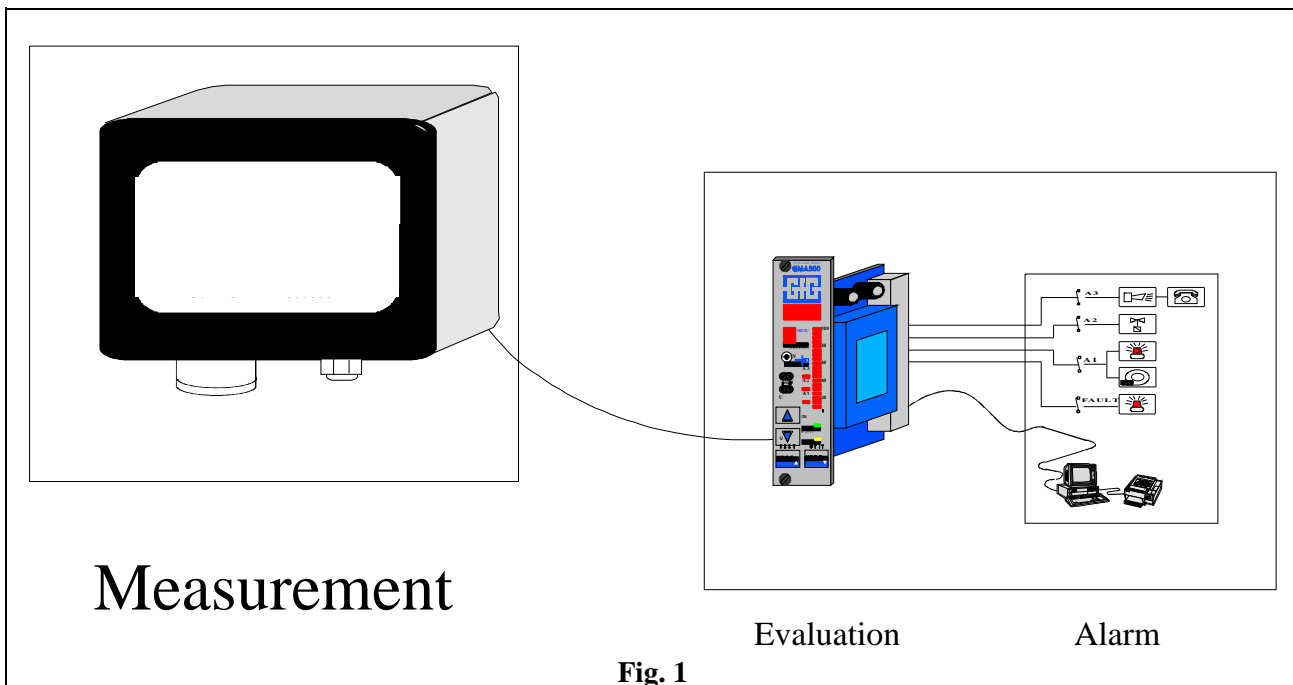

The CC 0238 is an "intelligent" transmitter. Its comprehensive electronic circuitry allows easiest handling and servicing and increases the measurement reliability and accuracy. The CC 0238 is characterized by following features:

- Easy calibration at site.
- Compensation of temperature effects.
- Tested for function in the temperature range from -25 to +55 °C

Detection Principle

The CC 0238 is operated on the detection principle "catalytic combustion" (fig.2). The gas/vapour-air mixture enters the sensor chamber by diffusion through the sinter filter. Inside the sensor chamber there are an active and a passive sensor filament. The heated active sensor burns (oxidizes) the gas entering. This increases the temperature at the sensor and results a change of the electrical resistance, which is the measure for the gas concentration. The passive (reference) sensor is exposed to the same ambient conditions as the active (detection) sensor and is used for compensation of environmental effects (e.g. temperature changes).

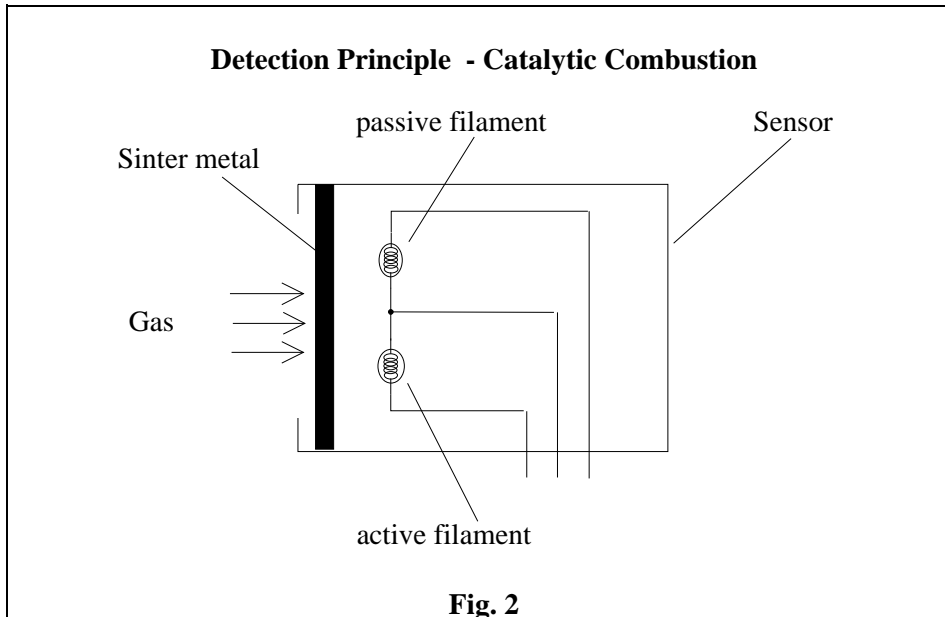

Operational Notes

According to § 26 a "UVV Gase" (VBG 61) (German Regulation for Preventing Accidents), gas warning instruments have to pass a function test, done by a specialist, after having been installed but before put in operation.

Before shipment, the CC 0238 passes a function and display test, being calibrated with suitable test gases. **This does not, however, overrule the obligation to arrange for another function test after putting the transmitter in operation.**

Design

The design of the CC 0238 is shown in fig. 3.

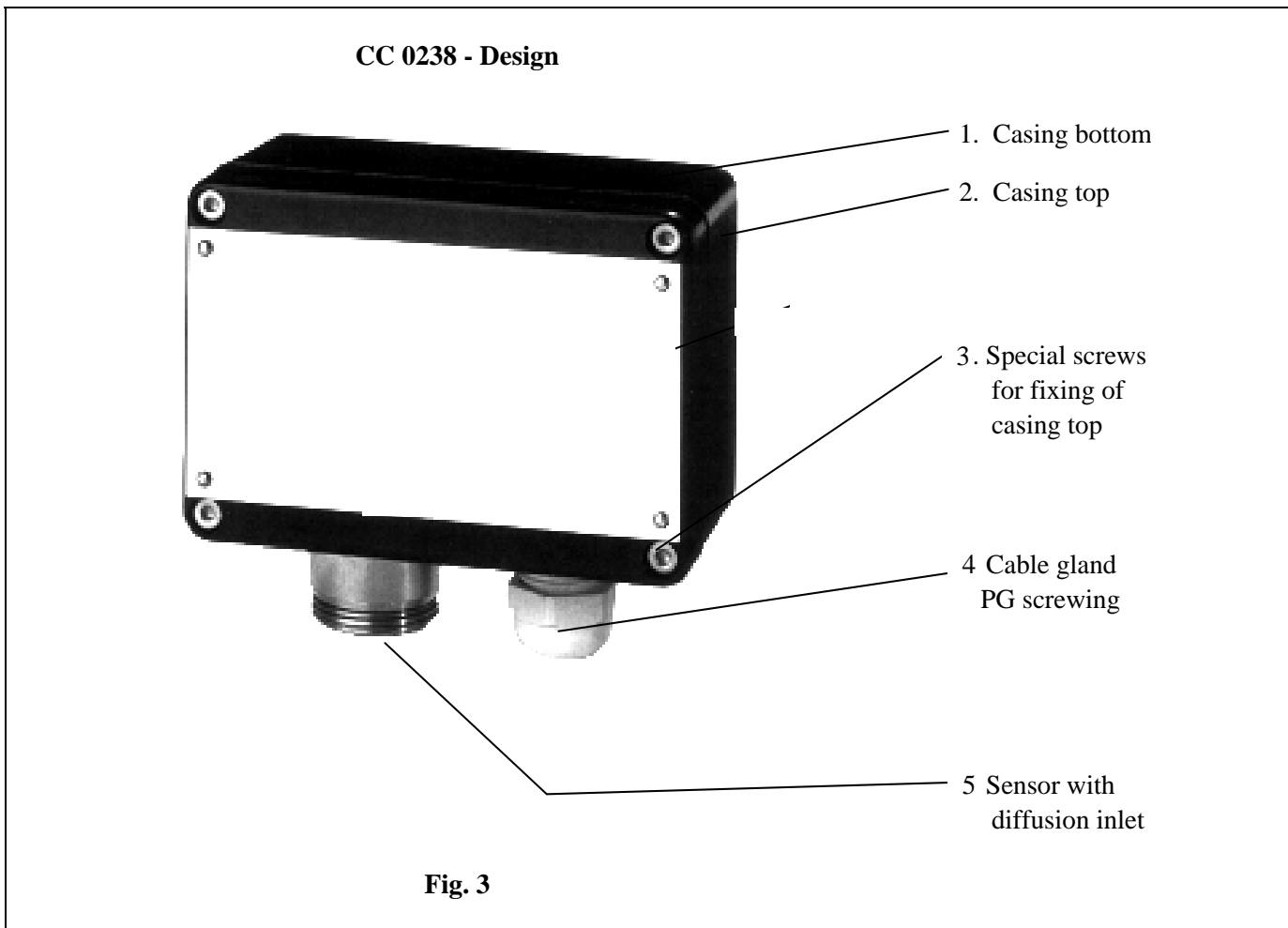

The sensor sleeve (Pos. 5) includes the sensor and the sensor card, which carries the components for the sensor circuitry. For adjustment of electrical zeropoint and sensitivity you find the respective potentiometers behind the service lid. The Transmitter casing contains the main p.c.board. The electronics on the main p.c.board converts the sensor signal into an output signal of 0,2 .. 1 mA.

The sensor is built into the sensor chamber (pos. 5). For adjustment of the electrical zeropoint you will find a potentiometer below the casing top (pos. 2). The printed circuit board inside the casing is sealed in epoxy resin.

Mounting Position of CC 0238

It is essential to exactly know the ambient conditions, which have to be taken into consideration before deciding on the mounting position. To achieve representative measurement results, take into account:

- the **room ventilation and**
- the **gas density**.

Install the CC 0238 at a place where the gases pass the sensor even in case of bad ventilation. If necessary, use a smoke cartridge to check.

In case the gas to be measured has a higher density than air, the transmitter is to be installed close to the floor. For lighter gases, with a lower density than air, the transmitter is being mounted close to the ceiling. The following chart shows the density of the tested gases. More detailed information are available on request.

Type of gas	rel. gas density (air = 1)	Mounting recommended
Methane CH ₄	0,55	close to ceiling
Propane C ₃ H ₈	1,56	close to floor
n-Nonane C ₉ H ₂₀	4,43	close to floor
Ethanol C ₂ H ₅ OH	1,59	close to floor

Furthermore, take the following into consideration as well:

- **Rain water, hose water, dripping water, condensate and**
- **Dust in the atmosphere.**

The CC 0238 is to a great extent protected against the entering of water and dust (IP 56). Special accessories are available to provide additional protection for very difficult conditions. Please contact GfG for detailed information.



Warranty may be voided, if the sensor is exposed to ambient conditions which were unknown to GfG during planning, production or delivery.

Mounting

When deciding on the position for the transmitter, make sure that it is always accessible for service and maintenance. The CC 0238 must be mounted with the sensor showing to the floor.

The CC 0238 is connected to the controller according to the Connection Diagram CC 0238 (page 11). For mounting the transmitter remove the four special screws (pos. 3, fig. 3) and take the casing top off. Fix the casing by means of two screws through the relevant borings.

The printed circuit boards inside the casing are potted in epoxy resin. In front of the potted block you will find the terminals for the sensor and the connections to the controller.

Installation of Electrical Connections

Procurement of cable and electrical connections must be done by a specialist only, obeying the applicable regulations. Installation has to be done using a 3 conductor 18 AWG shielded (e.g. LIYCY 3 x 1.5 mm²). The cross section of the cable depends on the cable length. For short distances (max. 200 m) it may be sufficient to use 20 AWG (0.75 mm²) instead of 18 AWG (1.5 mm²). For longer distances the cross section must be 18 AWG (1.5 mm²). The cable length must not be more than 1000 m.

The shield is fixed to the PG screwing. In case the Transmitter is mounted to electrically conductive undergrounds (e.g. steel girder), a potential compensation is to be effected.

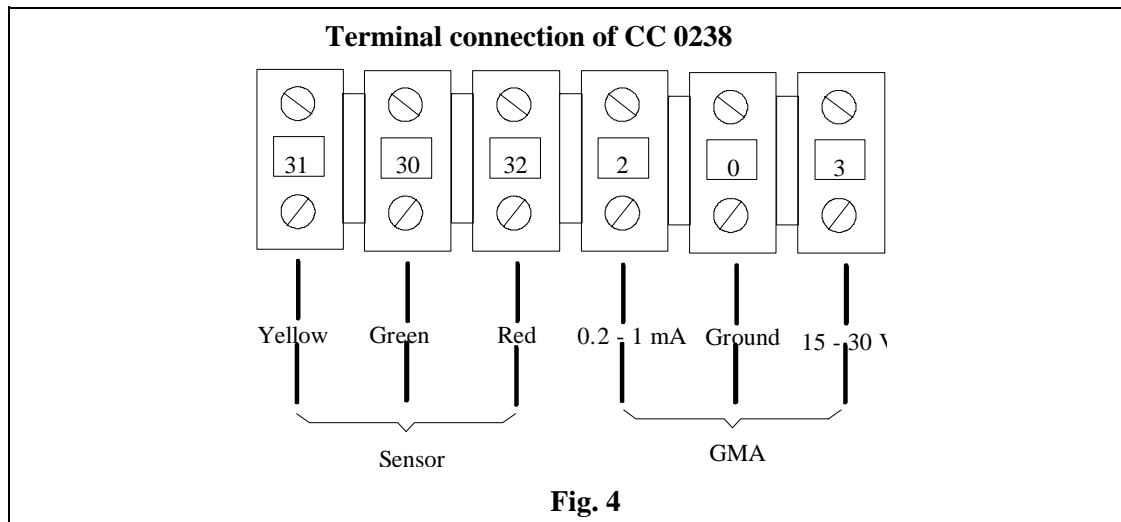

Installation and opening of the transmitter must always be done in gas-free air.

Putting into Operation

Once the MWG is installed, a skilled person can put it in operation. Before shipment, the MWG has been calibrated and tested after a running-in time of several days. You do not have to wait for so long, but once you have started your new CC 0238, the catalytic combustion sensor needs a certain running-in time of approx. 15 - 30 minutes before you can check the sensitivity. Allow another 10 minutes as warm-up time for the MWG. Should you notice that a re-calibration is required, allow the transmitter to warm up for about 24 hours.

Check of Electrical Zeropoint

The CC 0238 is calibrated and tested before shipment. Certain deviations, however, are possible due to transport, mounting and ambient conditions. Allow a warm-up time of about 15 to 30 minutes before checking the electrical zeropoint. Once the warm-up is finished, press  at GMA 100 controller (please read the operation manual for your GMA) to check the electrical zeropoint. Instead of U_M you may also measure the current in the "0.2 - 1 mA line" directly at the transmitter (terminal 2, see fig. 4). For checking the zeropoint make sure that the transmitter is operated in fresh air (without any combustible gases).



It is not allowed to open the transmitter in rooms with an explosible atmosphere. Any work at the sensor must only be done, if the presence of explosible mixtures can be excluded for the duration of work.

At the potted block you find two sealed potentiometers. Never turn the red one (sensor voltage)! The potentiometer with the green sealing lacquer is meant for adjusting the zeropoint (0.2 mA in the transmitter line).

Adhere to the following procedure for checking the electrical zeropoint:

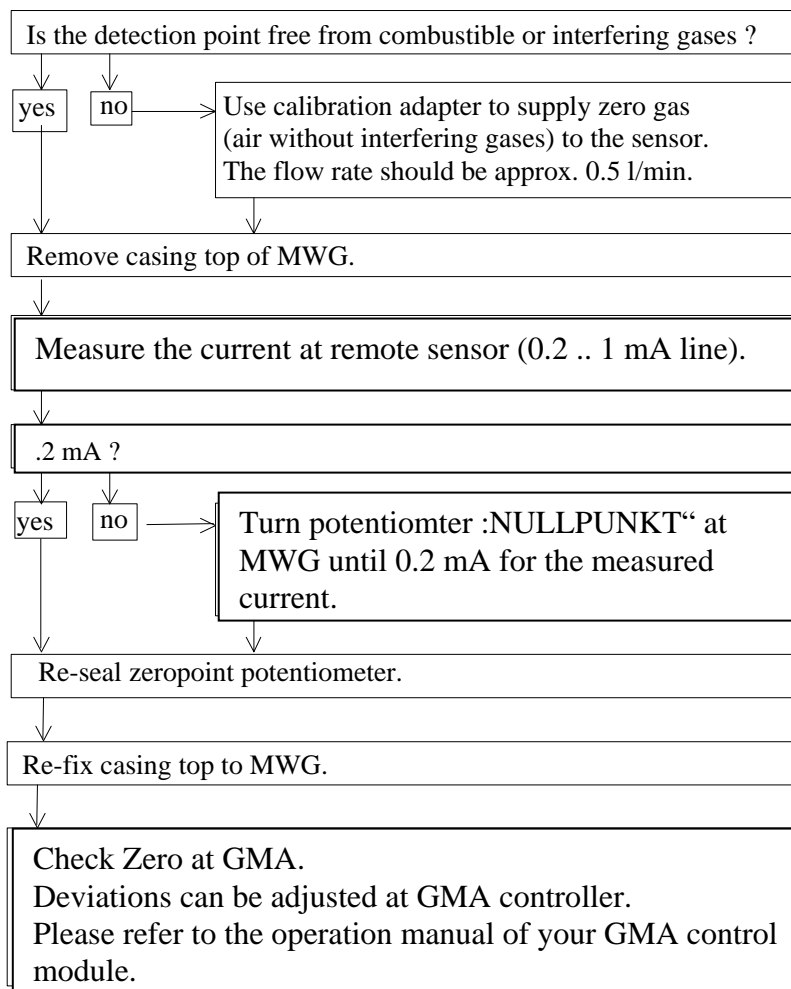

Once the zeropoint adjustment is completed, re-seal the potentiometer.

Check of Sensitivity

Before checking or adjusting the sensitivity, make sure that the electrical zeropoint has been set properly. Fix a test gas adapter on the diffusion inlet for checking the sensitivity (please also refer to the operation manual of your GMA

controller) and select a suitable test gas. Then check which gas has been used for initial calibration of the transmitter. You can see this information from the test report and from the type label at the transmitter. The test gas concentration should be at least 20 % above the second alarm threshold. Please refer to the test report of the transmitter for the basic adjustment of alarm thresholds and full scale. Do not use a test gas concentration with a balance of nitrogen. Adhere to the following procedure to check the sensitivity:

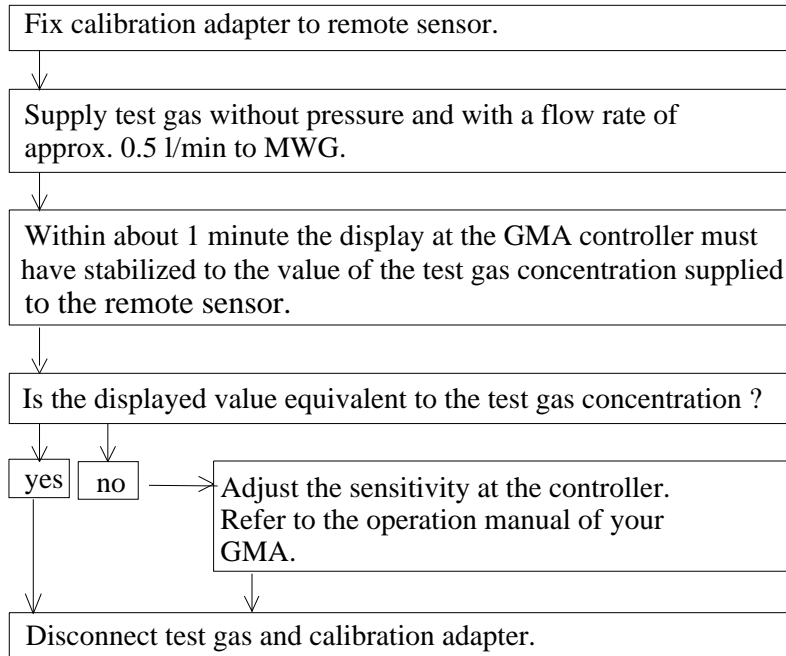

Signal Transmission

Depending on the type of gas, the CC 0238 is characterized by different transmission of signals, i.e. the response time, the signal value and the transmission curve may be different. For example: The transmitter provides an almost linear signal for gases like propane, ethanol and nonane, but a non-linear one for methane.

Service

According to the German "Regulation for Explosion Protection", "UVV-Gase" and DIN 31051, service stands for maintenance, inspection and repair of gas warning equipment. Regulation T023 of "BG Chemie" describes the relating measures, among others requesting a regular function check.

This function check means:

- Check with alarm gas concentration
- Check of zeropoint and sensitivity (calibration)
- Check of response time
- Check of gas sampling and gas processing system (if any)
- Check of alarm signal activation
- Check of failure alarm

The check must be done by an expert, who has to report the result in written form.

Maintenance and Inspection

Maintenance and inspection mean measures which ensure the planned status of the gas monitoring system. Maintenance and inspection also mean a regular check and adjustment of zeropoint and sensitivity as well as a functional check of the system. Generally the calibration intervals should not exceed 16 weeks. The function check is to be done before putting the system in operation, and it has to be done at least once a year.

Depending on the ambient conditions, gas monitoring systems may show a different behaviour. It is important, therefore, to do a visual check every day, particularly during the first few days after putting in operation (see T023).

- Check of gas processing system and filters (if any).
- Check of gas supply for soiling or obstacles (for correct measurement the gas supply to the sensor must not be blocked).
Check with test gas.
- Sensors are subject to ageing and exhausting. Depending on their type and on their exposure to gas they are more or less used up, so a sensitivity check can only be done with a suitable test gas after certain periods. The sensitivity calibration is an expert calibration and is usually done by GfG's service or by authorized persons.

It is recommended to call GfG service for the above.

Functional Restrictions depending on Oxygen Concentration

Please note that measurement of gas and/or vapour concentrations in the range below 100 % LEL cannot be done accurately, if the oxygen concentration is below 10 Vol.-%. In this case there is not sufficient oxygen to allow the catalytic combustion at the sensor.

Display Irritation due to Sensor Poisons

Certain parameters, known as „sensor poisons“ or „catalyst poisons“, may affect the signal behaviour of the sensor. The "sensitivity", i.e. the capability to emit signals, is being reduced. Sensor poisons are e.g. sulphur, lead and silicon vapours. Usually these components are found very rarely or in very low concentrations only.

Please draw your special attention to any interfering gases, which might be present at your detection place and which might affect the proper functioning of your gas monitoring system. Depending on the type of gas and its concentration, this effect may be a slight loss of sensitivity or even a sudden death of the sensor.

Trouble Shooting

Failure	Reason	Solution
Zeropoint cannot be adjusted	Faulty sensor	Replace sensor
Measurement value at control unit cannot be set to test gas concentration	Faulty sensor	Replace sensor
Output current has fallen to 0 mA	Faulty electronics Cable cut	Replace electronics Re-fix connection

Accessories

Screw-on calibration adapter (flow rate 0.5 l/min \pm 0.1 l/min)

Part No.
200209

Spare parts and accessories should be stored at ambient temperatures of 0 ... 30°C. Storage time should not exceed 5 years. For storing of spare sensors make sure that the ambient atmosphere is free from corrosive components and sensor poisons.

Connection Diagram CC 0238

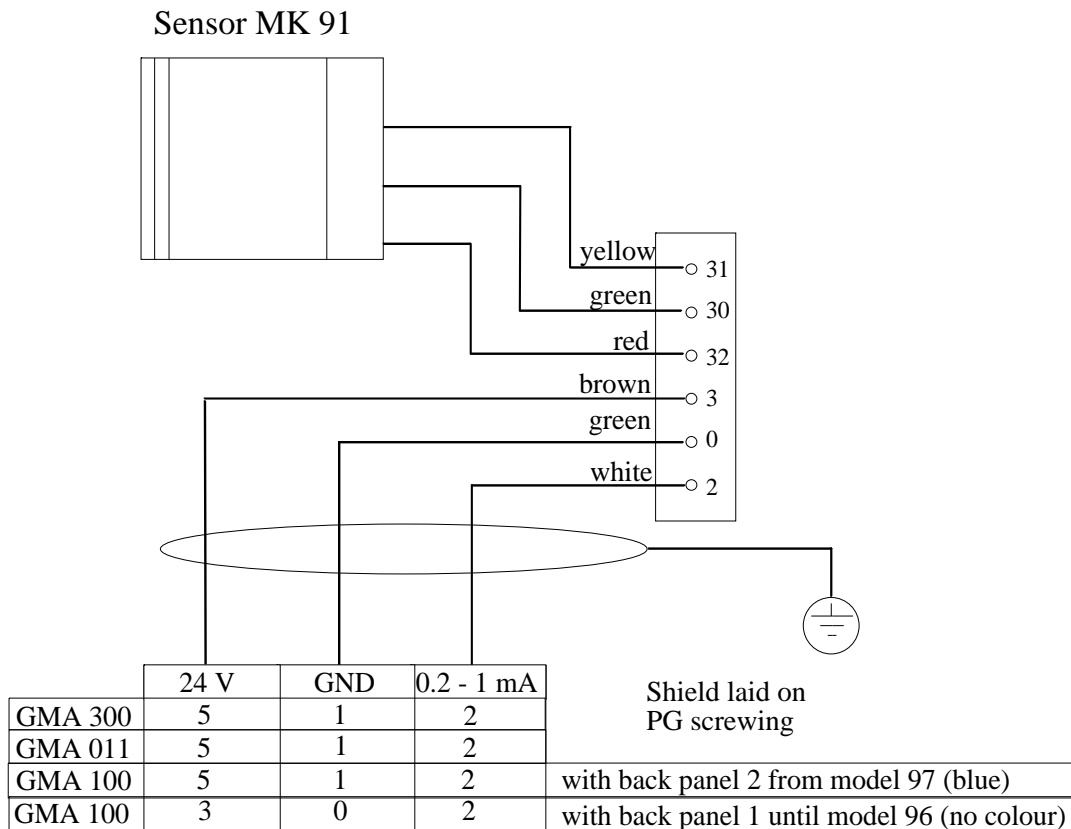

Lower Explosion Limit (LEL) of Tested Gases

Gas	LEL acc. to EN 50054 (Edition 1991)	LEL acc. to Redeker/Schön (6. Extension)
Methane, CH ₄	5,0 Vol.-%	4,4 Vol.-%
Propane, C ₃ H ₈	2,0 Vol.-%	1,7 Vol.-%
n-Nonane, C ₉ H ₂₀	0,7 Vol.-%	0,7 Vol.-%
Ethanol, C ₂ H ₅ OH	3,3 Vol.-%	3,5 Vol.-%

Technical Data

Transmitter

Type:	CC 0238
Sensor Type:	MK 91
Sensor Life:	> 5 years
Gas:	Combustible gases and vapours, e.g. methane, propane, ethanol, n-nonane (see test report)
Range:	0 .. 100 % LEL
Response Time T ₉₀ :	< 30 s (depending on type of gas)
Detection Principle:	Catalytic combustion
Gas Supply:	Diffusion or via calibration adapter (flow rate 0.5 l/min ± 0.1 l/min)
Supply Voltage:	24 V DC +/- 10%
Output Current:	0.2 .. 1 mA

Climate Conditions

Storage Temperature:	0 .. 30 °C
Operational Temperature:	-25 .. +55 °C (function tested)
Humidity:	5 .. 90 % r. h. Non condensing
Atmospheric Pressure:	950 .. 1100 hPa

Climate Effect acc. to EN 50057

Temperature	-10 .. +40 °C	(20 °C) ± 3 % of full scale or ± 10 % of indication
Temperature	-25 .. +55 °C	(20 °C) ± 7 % of full scale or ± 15 % of indication
Pressure	950 .. 1100 hPa	(1013 hPa) ± 5 % of full scale or ± 15 % of indication
Humidity	5 % .. 90 %	(55 %) ± 5 % of full scale or ± 15 % of indication

Casing

Casing Material:	Anti-static compound
Cable Gland:	PG 11 screwing
Cable Type:	3 conductor 18 AWG shielded; LIYCY 3 x 1,5 mm
Cable Length:	up to 1000 m
Dimensions:	110 x 75 x 55 mm (WxHxD)
Weight:	approx. 600 Gramm
Casing Protection:	IP 56

Index

Design, 5.
Detection Principle, 4
Dust, 6
Electrical Connections, 6
Inspection, 10
Installation, 6
Maintenance, 10
Mounting, 6
Mounting Position, 5
Operational Notes, 4
Putting in Operation, 7

Safety, 3
Sensitivity Check, 9
Service, 9
Technical Data, 12
Trouble Shooting, 11
Type Label, 5
Ventilation Conditions, 5
Water, 6
Zeropoint Check, 8