

EC 36

Fixed Transmitter

Operations Manual



GfG Instrumentation

1194 Oak Valley Dr, Ste 20, Ann Arbor MI 48108 USA
(800) 959-0329 • (734) 769-0573 • www.gfg-inc.com

Content

	Page
General Description	1
Detection Principle	2
For Your Safety	2
Design	2
Mounting	3
Mounting Position of EC 36	3
Installation of Electrical Connections	3
Putting in Operation	4
Detection Mode	5
Check of Display and Parameter	5
Alarm	6
Fault	6
Relays	7
Check and Autocal Adjustment of Zeropoint	8
Check and Autocal Adjustment of Sensitivity	9
Service	10
Activation of Service Menu	10
Adjustments in Service Mode	11
Check and Adjustment of Calibration Gas Concentration CGAS	11
Check and Adjustment of Alarm Thresholds A1 resp. A2	11
Check and Adjustment of Hysteresis of Alarm Thresholds H1 resp. H2	12
Check and Adjustment of Alarm Functions P1 resp. P2	13
Check and Adjustment of Detection Range SCAL	13
Display of Software Version and Serial Number INFO	14
Leaving the Service Mode	14
Remote Controls	15
Single Key Control RP30	16
Remote Control RC30	16
Maintenance	17
Service and Inspection	17
Trouble Shooting	17
Gases and Detection Ranges	18
Accessories	19
Connection Diagram EC36 with 4 .. 20 mA Output	19
Technical Data	20

General Description

The EC36 is an "intelligent" measuring system in a pressure-proof enclosure for continuous detection of gas concentrations and for warning from toxic gases and oxygen deficiency in ambient air. The comprehensive electronics takes over many tasks which facilitate operation and service and considerably increase operational safety and measuring accuracy. Its special features are:

- Plug-in Smart Sensors
- Scalable detection ranges
- Big illuminated display
- Easy 3 button operation
- Handling even in Ex area
- AutoCal function
- Remote Control / Display
- Compatible with U.S. Conduit System

A 3-wire interface with 4-20mA output is the connection of the transmitter to the outer world. The EC36 provides an additional „Remote Interface“, which allows to handle and operate the unit over a distance of up to 30m even in Ex areas. The EC36 also provides two alarm relays, one fault relay and the relevant status displays. The backlight illumination allows to read the display even under bad lighting conditions.

The EC36 permanently indicates the measured gas concentration, exceeded thresholds and operational status. Should the gas concentration exceed one of the two pre-set threshold values, the EC36 gives an immediate warning by means of its LEDs and controls the relevant alarm relays. In addition to this, the EC36 provides the measurement value as an analog output signal for further processing.

The EC36 is easy to operate and maintenance-free. Should there be any faults or system failure, the comprehensive fault recognition of the EC36 allows a specific and quick service.

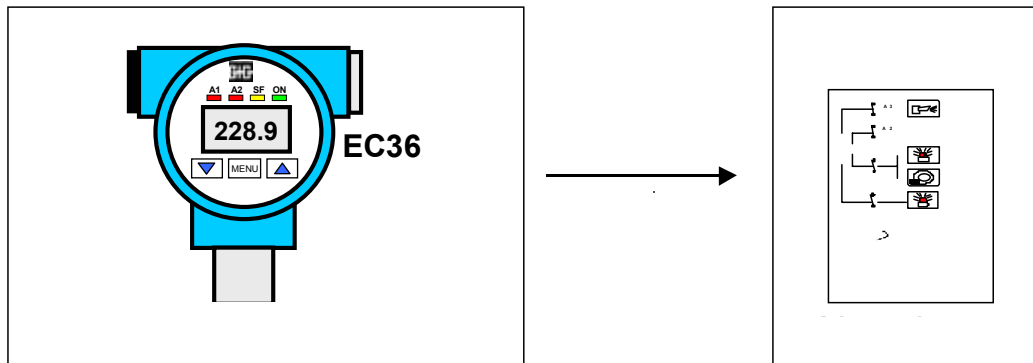

Detection Principle

The sensors used in the EC36 are electrochemical cells. Electrochemical cells consist of an electrolyte, a working electrode (anode), a counter electrode (cathode) and a reference electrode. The cells are adapted to the gas to be monitored by specific electrodes and a suitable electrolyte. The electrochemical reaction generates an electrical signal, which is proportional to the gas concentration. This signal is amplified by the EC36 and used for display resp. transmission. The sensor cells are using the capillary diffusion barrier technology, which, in combination with an additional temperature compensation, avoids effects caused by changing atmospheric pressure and temperature. Some sensor cells are available with a pre-filter to improve their selectivity.

For Your Safety

This manual points out the proper use of the product and serves to prevent dangers. It must be carefully read by all individuals who have or will have the responsibility for using and servicing this product. This product can only do the job designed to do, if it is used and serviced in accordance with the manufacturer's instructions. The warranties made by GfG with respect to the product are voided, if the adjustment of functions or parameters is changed without GfG permission. They are also voided, if the product is not used and serviced in accordance with the instructions in this manual. Please protect yourself and your employees by following them. The above does not alter statements regarding GfG warranties and conditions of sale and delivery.



For the set parameters please refer to the test report. Changing functions or parameters may affect the approval. Please contact your GfG service for adapting the detection system to your specific needs.

Design

The design of the EC36 is shown below. The type label indicates the type of transmitter. The sensor cell is built into the sensor holder.

The enclosure includes the main unit, consisting of display and main board, and the supply board. The electronics of the main unit converts the measurement signal for the display and the output. The supply board carries the connections for the voltage supply, the output and the relays.

For operating the buttons of the EC36 you must screw the casing top off.. This results in the loss of the explosion protection..

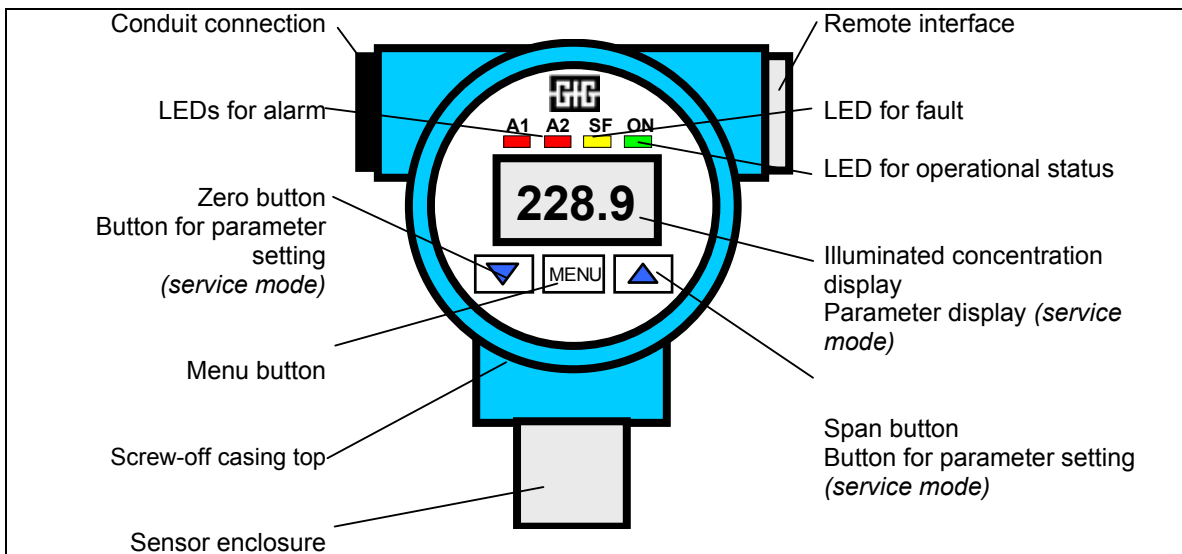

Mounting

Mounting Position of EC 36

It is essential to exactly know the ambient conditions, which have to be taken into consideration before deciding on the mounting position. To achieve representative measurement results, take care of

- the **room ventilation** and
- the **gas density**.

Install the EC36 at a place where the gases pass the sensor even in case of bad ventilation. If necessary, use a smoke cartridge to check.

Furthermore, take the following into consideration as well:

- **Rain water, hose water, dripping water, condensate** and
- **dust in the atmosphere**.

The EC36 is to a great extent protected against the entering of water and dust (IP 66).



Warranty may be voided, if the sensor is exposed to ambient conditions, which were unknown to GfG during planning, production or delivery.

When deciding on the position make sure that the transmitter is always accessible for service and maintenance. It is recommended to mount the EC36 with the sensor showing to the floor. Different installation, however, does not affect the measurement accuracy.

Installation of Electrical Connections

Procurement of cable and electrical connections must be done by a specialist only, obeying the applicable regulations.

Depending on the model or the operation of the EC36, a shielded 3-core or multi-core cable has to be used (3 conductor 18AWG shielded max. 200 m).

To install the connections, screw the casing top off and pull the main unit off the supply board.

Connection Diagram of Supply Board

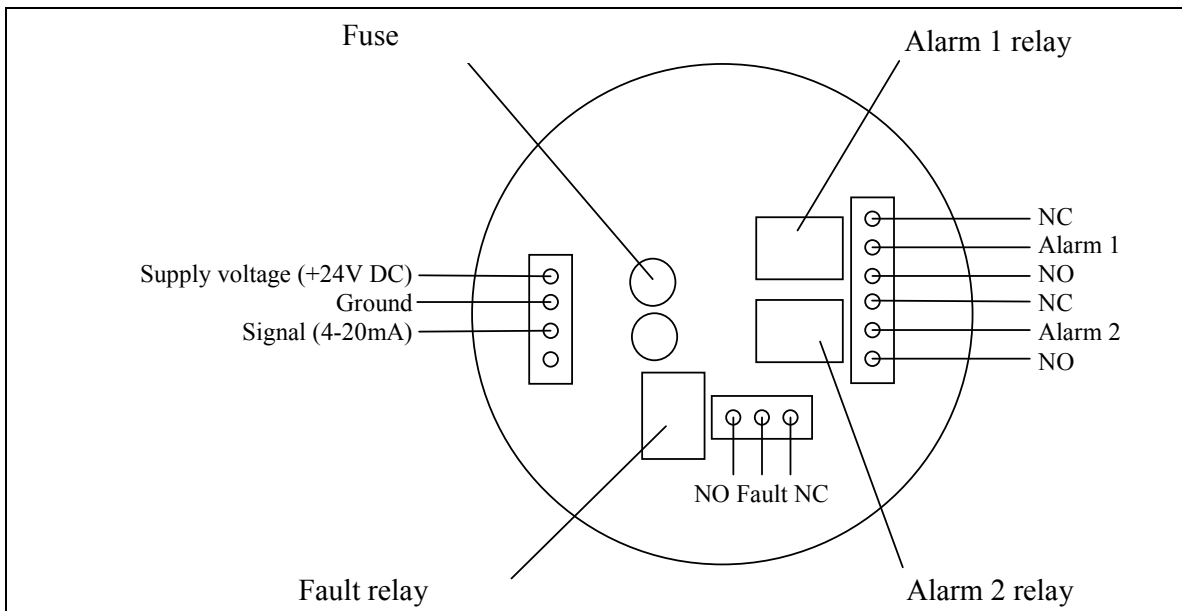

You can connect the EC36 directly to an evaluation unit by means of a 3-pole lead. The current consumption of the unit is approx. 250mA at an operating voltage of 24V DC.

	Way of procurement
U.S.A.	The leads are procured inside a tubing system (conduit), which is mechanically connected to the enclosure. In regular distances there are ignition interlocks (seal) to prevent the extension of a possible explosion inside the conduit.
Europe	The lead is made in ignition classification „increased safety“. Inside the EC36 enclosure is a terminal box. This box and the enclosure are connected by means of a pressure-proof gland.

Once the installation is completed, plug the main unit back to the supply board and screw the casing top on again.

The EC36 can be connected to an evaluation unit according to the terminal diagram.

Putting in Operation

The EC36 is tested for function and indication before shipment. Calibration was done with the proper test gases. Certain deviations, however, are possible due to transport, mounting ambient conditions. Recalibration may be necessary.

After turning on, allow several minutes for:

- the self-check, which tests functions, memory (ROM and RAM) and parameter memory (approx. 10 seconds),
- the warm-up of the sensor.

During the warm-up time the EC36 indicates unit of measurement, kind of gas, detection range, alarm thresholds AL1 and AL2 and the calibration gas concentration one after the other. On the EC36 the LED „ON“ flashes and the LED „F“ is lit, i.e. the fault is activated. Threshold alarms are not activated during the warm-up period. When the EC36 re-starts after a mains failure, the gas alarms are only evaluated, once the warm-up is completed. Then the EC36 turns automatically to detection mode.

Allow a warm-up time of 30 minutes before checking the zeropoint. After this time the display should have stabilized to read „000“. Depending on detection range and sensor the display may also read 20.9 (O₂) or 0.00 (Cl₂).

Detection Mode

In detection mode the digital display indicates the present gas concentration. Measurement is done continuously. The EC36 recognizes and reports exceeded thresholds immediately. Electronic functions like parameter memory sensor are monitored permanently. During trouble-free detection mode the green LED „ON“ is lit, while the yellow LED „F“ is out.



Every minute the display shortly reads the unit of measurement and the kind of gas as operational signal.

Check of Display and Parameter



During these checks the measuring and warning functions are not active!

Display Test

In detection mode shortly press  to start a display test. The display reads all segments •••••.

Indication of Detection Range and Alarm Thresholds

For indication of detection range and alarm thresholds press . The display reads the parameters below, one after the other:

	Display, i.e.	Description of display
1	UEG, LEL, VOL, PPM	Unit of measurement
2	CH₄, NH₃, O₂	Gas
3	SCAL / 200, 100, 50	Detection range
4	A1 / 25 (value within range)	1. Alarm threshold
5	A2 / 50 (value within range)	2. Alarm threshold
6	CGAS / 50 (value within range)	Calibration gas concentration

Once the display is finished, the EC36 returns to detection mode automatically.

This display sequence is also shown after turning on and in connection with the different remote control systems.

Alarm

The EC36 provides 2 alarm thresholds. An alarm is triggered as soon as the gas concentration exceeds or falls below an alarm threshold. The EC36 indicates a threshold alarm by means of the relevant alarm LED. Press or the external reset to acknowledge an activated alarm.

The EC36 activates the relevant alarm relay simultaneously with the alarm LEDs. In the standard setting the switching function of the alarms are as shown below:

Alarm	Function	Re-settable <i>during gas alarm</i>	Re-settable <i>after gas alarm</i>	Remark
1	non-latching	no	no	
2	latching	no	yes	can only be reset, if alarm thresholds are exceeded or fallen below

Notes in regard to alarm functions:

Exceeding/deviating alarm

When you measure gases which cause danger by falling concentrations, e.g. oxygen deficiency, the threshold alarm is a deviating one. When a hazardous situation is caused by rising gas concentrations, e.g. by toxic and combustible gases, the threshold alarm is an exceeding one.

Latching / non-latching alarm

A latching alarm remains active until external measures, e.g. pressing , resets the alarm. A non-latching alarm turns off automatically as soon as the gas hazard is reduced and the gas concentration falls below or exceeds the relevant threshold.

Fault

A fault is indicated by the yellow LED „F“ and the fault relay. Fault is signaled, if:

- the sensor or the transmitter electronics is faulty
- no sensor is fit
- the sensor life has expired
- the self monitoring function detects a failure

Once the fault is cured, the yellow LED „F“ goes out, the fault relay switches back and the EC36 returns to the standard detection mode.

























Relays

The EC36 provides 3 relays:

- 2 alarm relays for activation of external alarm devices, valves, etc.
- 1 fault relay for failure report.

The switching behaviour of the relays is the same as for alarm or fault signals. Every relay is of change-over type and can be operated as NC or NO contact in closed or open circuit systems. For the switching functions as NC and NO relays you will find contact clamps. In the standard setting all 4 relays are NO contacts. The alarm relays are standard operated as open circuit system, the fault relay is a closed circuit.

In the standard setting the switching function of the relays is shown below:

Relays for:	The relay switches:							
	in detection mode (no gas)	during gas alarm		after gas alarm		during mains failure	during failure	during gas alarm and failure
		not reset	reset	not reset	reset			
Alarm 1								
Alarm 2								
Fault								





It is essential to take note of the switching behaviour of the relays when connecting external devices.

Check and AutoCal Adjustment of Zero point

This check for TOX sensors is subject to the presence of atmospheric air without interfering gas components. Otherwise you have to supply synthetic air to the sensor. An oxygen sensor has to be exposed to 100 Vol.-% nitrogen (N₂) to check and adjust.

Fix a calibration adapter on the sensor holder. Supply synthetic air (or 100 % N₂) without pressure at a flow rate of approx. 0.5 l/min. Look at the display. If it is different from 0, you have to adjust the zero point. When the display value is constant, the zero point adjustment can be done by means of the AutoCal program. The AutoCal program provides the automatic setting of the zero signal to the zero gas.

1. Press  for min. 3 seconds to activate the AutoCal program.
2. The display shows alternately the present measurement value and the indication **ZERO**. If the measurement value remains constant during a defined period, it is overwritten by the zero value. The AutoCal program then stops automatically.

The AutoCal program can be shortened by long-term pressing of . The display shortly reads **SAVE** and the measurement value is overwritten by the zero value.



Should you want to leave the AutoCal without zero point adjustment, just press  shortly. The display shortly reads **ESC**.

During adjustment, the following error messages may be reported:

Display	Remark
CAL ERR.1	No test gas recognized
CAL ERR.2	Test gas signal is unstable
CAL ERR.3	Calibration data does not make sense

Error messages during adjustment procedure have to be acknowledged by pressing .

Check and AutoCal Adjustment of Sensitivity

First check the calibration gas concentration: Refer to the test report or shortly press  to read the parameter from the display. The test gas concentration should be at least 20 % above the 2. alarm threshold. The alarm settings can also be seen from the parameter display after shortly pressing .





Dealing with toxic gases requires special safety measures. TLVs give hints in regard to hazards caused by toxic gases.

Fix a calibration adapter on the sensor holder.

Supply the test gas (fresh air or synthetic air for adjustment of an oxygen sensor) without pressure at a flow rate of approx. 0.5 l/min. Look at the display. If the display value is different from the test gas concentration, a sensitivity is necessary. When the display value remains constant, the sensitivity adjustment can be done by means of the AutoCal program. The AutoCal program provides the automatic setting of the measurement signal to the test gas.

1. Press  for min. 3 seconds to activate the AutoCal program.
2. The display shows alternately the present measurement value and the indication **SPAN**. If the measurement value remains constant during a defined time interval, it is overwritten by the test gas value. The AutoCal program then stops automatically.

The AutoCal program can be shortened by long-term pressing of . The display shortly reads **SAVE** and the measurement value is overwritten by the value of the test gas concentration.

Should you want to leave the AutoCal without sensitivity adjustment, just press  shortly. The display shortly reads **ESC**.

During adjustment, the following error messages may be reported:

Display	Remark
CAL ERR.1	No test gas recognized
CAL ERR.2	Test gas signal is unstable
CAL ERR.3	Calibration data does not make sense

Error messages during adjustment procedure have to be acknowledged by pressing the .

Service





Activation of Service Menu

The service menu allows to select and to change all important parameters of the EC36.

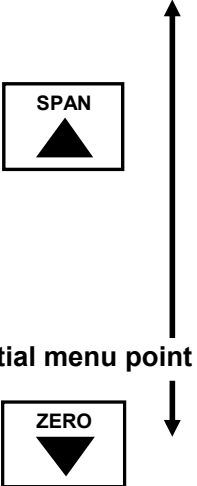
Here is how to reach the menu:

1. Press  for at least 3 seconds. The display reads **CGAS**. Use the navigation keys to select the different menu points.





	Menu Display	Description
	INFO	Display of software version and serial number
	SCAL	Changing of detection range
	P2	Changing of alarm function for Alarm 2
	P1	Changing of alarm function for Alarm 1
	H2	Changing of hysteresis for Alarm 2
	H1	Changing of hysteresis for Alarm 1
	A2	Changing of alarm threshold for alarm 2
	A1	Changing of alarm threshold for alarm 1
	CGAS	Changing of calibration gas concentration
	SAVE	Leaving detector settings with storing of changed parameters
	ESC	Changing of detector settings without storing of changed parameters

Shortly press  to activate the requested menu point once you have selected it. For adjusting the parameters use  and . Shortly press  again to leave the menu point.





In the service mode the threshold alarms are blocked. The EC36 turns to fault. The LEDs "ON" and „F“ are lit, the fault relay is activated.

Adjustments in Service Mode

Check and Adjustment of Calibration Gas Concentration CGAS

1. Shortly press  to activate menu point **CGAS**.
2. The display shows the currently set value for the calibration gas concentration.
3. Use  and  to adjust the parameter.
4. Shortly press  to leave menu point **CGAS**.
5. Store the parameter (see page 14)

Check and Adjustment of Alarm Thresholds A1 & A2

1. Shortly press  to activate menu point A1 resp. A2.
2. The display shows the currently set value for the alarm threshold.
3. Use  and  to adjust the parameter.
4. Shortly press  to leave menu point A1 resp. A2.
5. Store the parameter (see page 14)

Check and Adjustment of Hysteresis of Alarm Thresholds H1 and H2





This function allows to adjust the hysteresis (de-activation point) of the alarm thresholds. The setting of the parameter is effected in the unit of the gas to be measured.

Example:

The de-activation points for alarm 1 and alarm 2 of an EC 36, which provides a detection range of 0 .. 100 ppm, have been set to 4 ppm below alarm 1 and to 10 ppm below alarm 2. This results in alarm activation as shown below:

	Alarm 1	Alarm 2
Alarm threshold	= 10 ppm	= 50 ppm
Alarm activation	≥ 10 ppm	≥ 50 ppm
Hysteresis	4 ppm	10 ppm
Alarm de-activation	≤ 6 ppm	≤ 40 ppm

Adjustment of Hysteresis:

1. Shortly press  to activate menu point H1 resp. H2.
2. The display shows the currently set value for the hysteresis.
3. Use  and  to change the parameter.
4. Shortly press  to leave menu point H1 resp. H2.
5. Store the parameter (see page 14)



Check and Adjustment of Alarm Functions P1 and P2

1. Shortly press  to activate menu point P1 resp. P2.
2. The display shows the currently set code for the alarm function (see chapter Alarms).

Parameter Display	Description
L S.C	Deviating alarm, storing, always re-settable
L SC	Deviating alarm, storing, re-settable only when gas concentration exceeds the alarm threshold
L NS	Deviating alarm
H NS	Exceeding alarm
H SC	Exceeding alarm, storing, re-settable only when gas concentration has fallen below the alarm threshold
H S.C	Exceeding alarm, storing, always re-settable

Code

L Low	H High	S Store	N No Store	C Confirm
--------------	---------------	----------------	-------------------	------------------





3. Use  and  to set the parameter.
4. Shortly press  to leave menu point.
5. Store the parameter (see page 14)

Check and Adjustment of Detection Range SCAL



The scaling function of the EC36 allows to use one single sensor of the EC30 system for different detection ranges. This means that most applications are covered by max. 2 different sensors for one gas.

CO 500 ppm	0 .. 500 ppm	400 ppm	300 ppm	250 ppm	200 ppm	100 ppm
CO 2000 ppm	0 .. 2000 ppm	1000 ppm	500 ppm	400 ppm		
NH ₃ 2000 ppm	0 .. 2000 ppm	1000 ppm	500 ppm	400 ppm		
NH ₃ 1000 ppm	0 .. 1000 ppm	500 ppm	400 ppm	300 ppm	250 ppm	200 ppm

The max. detection range of the individual sensors can be scaled down to one sixth. This is based on the following raster: 10, 20, 25, 30, 40, 50, 100 ...etc.

1. Press  shortly to activate the menu point SCAL.
2. The display shows the currently set value for full scale.
3. Use  and  to set the parameter.
4. Press  shortly to leave menu point SCAL.
5. Store the parameter (see page 14)

Display of Software Version and Serial Number INFO

1. Press  shortly to activate menu point INFO.
2. The display shows the software version and the serial number.
3. Press  shortly to leave menu point INFO.

Leaving the Service Mode

You can leave the service mode either with or without storing the changed parameter:

With storing:

Press  shortly to activate menu point SAVE.

Without storing:

Press  shortly to activate menu point ESC.



You can change several parameters one after the other without storing them individually. One collective storing process once your settings are complete, is sufficient to store all parameters in the previously selected menu point.

Remote Controls

Remote control of the EC36 can be effected by different systems. This allows handling, e.g. calibration, even in hazardous areas. The remote control systems are defined by their function possibilities.

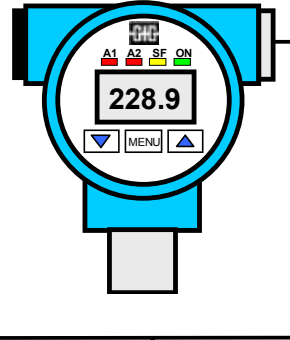

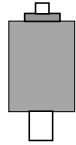
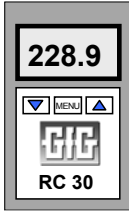
			
Description	Single Key Control	Remote Control	
Type	RP30	RC30	
Display	-	X	
Keypad	-	X	
Functions	AutoCal	all	
Memory for test gas concentration	X (max. 256 gases)	X (max. 256 gases)	
Remark	<p>Both the Single Key Control RP30 and the Remote Control RC30 provide a fuzzy electronic. If the calibration gas concentration for a certain gas is not programmed yet, the relevant data are automatically transmitted and stored from the connected transmitter.</p> <p>If gas and detection range are compatible, the test gas concentration stored in the remote control is transmitted to the transmitter via the connection. This allows easy calibration of several transmitters even in case of a different test gas concentration. The new test gas concentration is once set and stored with the remote control. When you are going to calibrate additional transmitters, these transmitters take the stored test gas concentration over from the remote control.</p>		

Once these remote control systems are connected to the EC36, the display shows measurement unit, gas, detection range, alarm thresholds AL1 and AL2 and the calibration gas concentration one after the other.

Single Key Control RP30

The single key control RP30 provides all functions for the calibration of the transmitter. The single key control includes an internal parameter memory, which stores calibration gas concentrations for different gases. When connected, the relevant value is transmitted to and stored in the transmitter. If the calibration gas concentration is changed, the new value is stored both in the transmitter and in the single key control.

The points mentioned in chapter „Check and AutoCal Adjustment Zero point / Sensitivity“ are also valid for the operation of the single key control RP30.

Zero point Adjustment

1. Press the key shortly to activate the AutoCal program zero point adjustment.
2. The display shows alternately the current measurement value and **ZERO**. If the measurement value remains constant during a defined time interval, it is overwritten by the zero value.

Long-term pressing of the key shortens the AutoCal program.

Press the key **shortly** to stop AutoCal without zero point adjustment.

Sensitivity Adjustment

1. **Long-term pressing** of the key activates the AutoCal program sensitivity adjustment.
2. The display reads alternately the current measurement value and **SPAN**. If the measurement value remains constant during a defined time interval, it is overwritten by the value of the test gas concentration.

Long-term pressing of the key shortens the AutoCal program.

Press the key **shortly** to stop AutoCal without sensitivity adjustment.

Remote Control RC30

The remote control RC30 provides all functions and adjustments, which can be done with the keys at the EC36.

As the single key control RP30, the remote control RC30 includes an internal parameter memory, which stores calibration gas concentrations for different gases. When you plug the connection cable in, the relevant value is transmitted to and stored in the transmitter. If the calibration gas concentration is changed, the new value is stored both in the EC36 and in the remote control.

Maintenance

The function test includes the check with alarm test gas and, if necessary:

- the check of zero point and sensitivity (calibration)
- the check of the response time
- the check of the gas sampling and gas processing system
- the check of the alarm signal activation
- the check of the fault alarm

This test has to be done by an expert, and a written result must be filed. The calibration intervals should not exceed 16 weeks. The function test has to be done before putting into operation and at least once a year.

Service and Inspection

Maintenance and inspection mean measures which ensure the planned status of the gas monitoring system.

The EC36 does not require a special maintenance, you should, however, take care of some points.

- Depending on the ambient conditions, gas monitoring systems may show a different behaviour. It is important, therefore, to do a visual check every day.
- Check of gas processing system and filters (if any).
- Check of gas supply for soiling or obstacles (for correct measurement the gas supply to the sensor must not be blocked).
- Electrochemical sensors are subject to ageing and exhausting. In general they need to be replaced after a period of 24 months. A sensitivity check can only be done with a suitable test gas. The sensitivity calibration is an expert calibration and is usually done by GfG's service or by authorized persons.

Trouble Shooting

Failure	Reason	Solution
Zero point cannot be adjusted	Faulty sensor	Replace sensor
Full scale cannot be adjusted	Faulty sensor	Replace sensor

Gases and Detection Ranges

Gas	Range	MK Type
Ammonia (NH ₃) for deep freezing applications	0...40 to 200 ppm 0...40 to 200 ppm	MK311-7 MK394-7
Ammonia (NH ₃) for deep freezing applications	0...200 to 1000 ppm 0...200 to 1000 ppm	MK399-7 MK400-7
Carbon monoxide (CO) (sensitive for H ₂ S)	0...100 to 500 ppm 0...400 to 2000 ppm	MK174-7 MK174-4
Carbon monoxide (CO) (not sensitive for H ₂ S)	0...100 to 500 ppm 0...400 to 2000 ppm	MK175-7 MK175-4
Chlorine (Cl ₂)	0...10 to 50 ppm 0...50 to 250 ppm	MK390-7 MK304-4
Chlorine dioxide (ClO ₂)	0...0.2 to 1 ppm	MK391-7
Ethylene oxide (C ₂ H ₄ O)	0...20 to 100 ppm	MK340-7
Hydrogen (H ₂)	0...400 to 2000 ppm 0...0.2 to 1 Vol.-% 0...1 to 4 Vol.-%	MK305-7 MK402-7 MK406-7
Hydrogen chloride (HCL)	0...40 to 200 ppm	MK309-7
Hydrogen cyanide (HCN)	0...10 to 50 ppm 0...40 to 200 ppm	MK409-7 MK336-7
Hydrogen sulfide (H ₂ S)	0...40 to 200 ppm 0...200 to 1000 ppm	MK176-7 MK177-7
Nitrogen dioxide (NO ₂)	0...10 to 50 ppm 0...40 to 200 ppm	MK310-7 MK310-4
Nitrogen monoxide (NO)	0...50 to 300 ppm 0...300 to 1500 ppm	MK179-7 MK179-4
Oxygen (O ₂)	0...5 to 25 Vol.-%	MK398-7
Ozone (O ₃)	0...1 to 5 ppm	MK397-7
Sulfur dioxide (SO ₂)	0...10 to 50 ppm 0...100 to 500 ppm	MK306-7 MK307-7
Silane (SiH ₄)	0...10 to 50 ppm	MK404-7

Accessories

	Part No.
Calibration adapter	2400209
Single Key Control RP30	2350230
Remote Control RC30	2350231

When replacing spare parts or using accessories please take the following effects on the detector characteristics into consideration:

Spare Part, Accessory	Effect of ambient temperature
Spare sensor	Zero point and full scale adjustment
Screw-in calibration adapter	None, if flow rate is 0.5 l/min
Plug-on calibration adapter	None, if flow rate is 0.5 l/min beträgt

Connection Diagram EC36 with 4 .. 20 mA Output

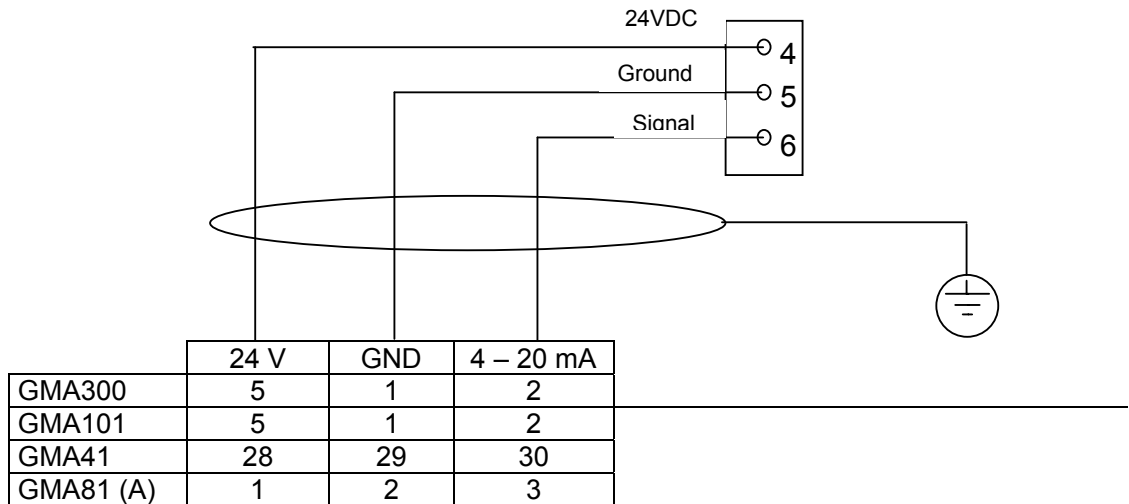

Technical Data

EC36

Type: EC36

Gas: Toxic gases and vapors, e.g. chlorine, ammonia or oxygen (see test report)

Range: see test report

Gas supply: Diffusion

Detection principle: Electrochemical sensor cell

Response time T_{90} : < 5 s (depending on gas and sensor)

Sensor life: Toxic gases and oxygen > 2 years

Power Supply

Supply voltage: 24 VDC

Current consumption: 250 mA

Output current: 4 .. 20 mA

Climate Conditions

Operational temperature: -15 .. +45 °C, 15 .. 96 % r. h., 920 .. 1080 hPa (depending sensor)

Outputs

Analog output: 4 .. 20 mA, max. load 300 Ω

Relays: max. switching voltage 250 V AC 50/60 Hz or 250 V DC

max. switching current 4 A AC/DC

max. switching performance 1000 VA AC or depending on voltage

50 .. 200 W DC

Relay outputs and mains connection are operation insulated

Remote Interface

Max. length of remote cable: 30 m (extended Remote Interface)

Enclosure

Material: Aluminum alloy

Material sensor holder: Stainless steel

Diffusion surface: Stainless steel, sintered

Cable gland: Screwing PG 9 max. cross section 3 x 1.5 mm²

Dimensions: 115 x 125 x 95 mm (WxHxD)

Weight: 1500 g

GfG Instrumentation, Inc.

1194 Oak Valley Dr.
Suite 20
Ann Arbor, MI 48108
USA

US/Canada: (800) 959-0329
US/Canada Fax: (734) 769-1888
International: +1 734 769 0573
International Fax: +1 734 769 1888
Website: www.gfg-inc.com



GfG Instrumentation

Worldwide Manufacturer of Gas Detection Solutions

7004-036 Rev 3 (Jul 10)