

RAM 4021-1

Operation Manual



GfG Instrumentation

Worldwide Manufacturer of Gas Detection Solutions

TABLE OF CONTENTS

RAM 4021-1

For Your Safety	3
Description	3
Setup Mode.....	4
Lights/Alarms	4
Operation	5
Calibration	6
Calibrating Carbon Monoxide Sensor with CO Test Gas.....	6
Manual Calibration of Oxygen Sensor	8
“ZERO/CAL” Adjustment for Carbon Monoxide	8
Maintenance	9
Oxygen Sensor Replacement	9
Carbon Monoxide Sensor Replacement	10
Troubleshooting	11
Zero Fail During CO Calibration.....	11
Calibration Gas Fail During CO Calibration	12
Accessories and Field Replacement Parts	12
Replacement Parts	12
Equipment Technical Data	13
Warranty	14

For Your Safety

Like any piece of complex equipment, the GfG Instrumentation RAM 4021 series will do the job it is designed to do only if it is used and serviced in accordance with the manufacturer's instructions. All individuals who have or will have the responsibility of servicing the equipment must carefully read this manual.

The warranties made by GfG Instrumentation with regards to this instrument are voided if the product is not used and serviced in accordance with the instructions in this manual. Please protect yourself and others who depend on this instrument by following these instructions. The above does not alter statements regarding GfG Instrumentation's warranties and conditions of sale and delivery.

Description

This unit is designed to provide continuous monitoring of carbon monoxide and oxygen levels in breathing air.

The instrument's electronics are enclosed in a NEMA-4X polycarbonate case. The case is corrosion resistant, positively pressurized by the compressor supply line, and sealed except for a bleed hole (to release the compressor's air). The unit operates on 110 VAC power. It comes equipped with a case-mounted horn that can be disconnected if it is not required.

Calibration adjustment controls are not necessary since they are automatically performed by the microprocessor.

The carbon monoxide chemical cell has a life expectancy of two to three years with a recommended 30-day calibration check. The oxygen sensor has a life expectancy of one to two years and may require periodic calibration.

Setup Mode

By briefly pressing the bottom switch it is possible to cycle through the setup parameters. Each time the bottom switch is pressed the display screen will identify the selected mode and indicate the current setup.

The following paragraphs outline the setup modes and options available. In each mode it is possible to change the setup using the top switch.

Lights/Alarms

YeLxx.x

-Low oxygen alarm, factory set to 19.5% volume.

YeHxx.x

-High oxygen alarm, factory set to 22.0% volume.

AutoC ON/OFF

-Set to on, the oxygen sensor will auto-calibrate every 24 hours.

CO Alm - XX

-The alarm point in parts per million is displayed (i.e. CO ALM 10).

Cal

-The parts per million of carbon monoxide to be used for calibration is displayed (i.e. CO - 20).

NOTE: This setup must be identical to the ppm concentration of the carbon monoxide calibration gas (5-100 ppm CO).

The carbon monoxide test gas concentration may be set from 5 to 100 ppm and is factory set to 20 ppm. It is important to use the same test gas as the "CAL" setting, otherwise the calibration will fail due to the error protection feature.

Changing the calibration gas concentration to another value without calibrating will fault (FLT) the unit's reading.

The FLT message may be removed by returning to the calibration value prior to changing or calibrating with the new test gas concentration.

CO # RLY

-The carbon monoxide alarm relay can be enabled (ON) or disabled (OFF) in this mode. The top switch will change this option.

Setting the relay ON or OFF permits any auxiliary device connected to the monitor to be shut off if it is not needed. During calibration it will be automatically shut off.

Test Mode Activates alarm, relays, LCDs, and solid squares on the LCD readout when the top switch is pushed.

The alarm horn and relays may be tested by pressing and holding the top switch while in alarm test setup mode. When testing an auxiliary horn, be sure the relay is turned ON.

Operation

Plug the unit into a 110 VAC outlet and the display will show introductory messages and a warm-up countdown. If the unit does not power up, check the electrical connections and try re-plugging in the unit. If start-up does not occur, call the factory.

After the warm-up countdown, the instrument will display CO and O₂ readings. The air regulator may be adjusted at any time to set the flow level from 0.5 to 0.9 CFH. If the **low flow** indication shows on the display, increase the flow to 1 CFH and then drop the flow to the operational range of .5 to .8 CFH.

CAUTION: If the unit is reading a carbon monoxide gas level, do not make any adjustments for a few hours until the unit has settled in. If calibration is attempted within the first fifteen minutes, a **TOO SOON** message will occur on the display.

If the carbon monoxide gas readings remain high or below zero (-0), recalibration may be needed. We also recommend checking the compressor's air intake, which may be the cause of high readings.

Outside air intake is recommended, but can easily be contaminated by furnace exhaust, building vents, parking lots, etc. Intakes within the building are to be avoided because they often contain low ppm levels of carbon monoxide.

The oxygen sensor may require manual calibration if the oxygen reading is greater than +/- 0.5% of 20.9% volume.

Calibration

Calibrating Carbon Monoxide Sensor with CO Test Gas (recommended every 30 days)

Although the unit is calibrated at the factory, it may require carbon monoxide recalibration due to handling. The only way to ensure that the sensor is operating properly is to test it with calibration gas.

To calibrate the unit with carbon monoxide test gas, shut off the air from the compressor supply line with the regulator and a **LOW FLOW** message will appear. Assemble the calibration kit and connect the tank of test gas to the calibration port connector on the instrument. Open the gas valve (use only the fixed flow regulator provided with the calibration kit). The display will read "CAL GAS" and a 60 second countdown will begin.

If the compressor air supply line is not shut off, a message will appear: **SUPPLY OFF**. If such a message occurs, shut off the supplied air and then begin the calibration process again to activate the calibration port switch.

After 60 seconds, a gas reading will appear along with a COUNT NUMBER. With 20 ppm of test gas applied the gas reading should be 20 and the count 70. At 70 counts with 20 ppm CO the unit will automatically calibrate.

The count number is also used for troubleshooting (see troubleshooting section). After the unit auto calibrates, a message will appear: **CO G SET**, indicating that the CO gain adjustment has been set for 20 ppm. Next an informational message on the automatic control pot value is displayed which also can be used in troubleshooting.

If an incorrect gas concentration is used or the sensor and/or instrument is not properly functioning, a message will appear: **CO G FAILED, PREV CAL, END CAL**. This affords improper calibration protection and an effort should be made to understand why it did not calibrate (see troubleshooting section for assistance).

After proper calibration, the next messages will be **REMOVE CALIBRATION GAS, END CAL, SUPPLY ON**. This prompts the calibrator to remove the test gas and turn the supply on at the regulator.

The oxygen sensor has a special AutoCal[®] mode that activates calibration every 24 hours. The instrument is shipped with this mode enabled. This function will reset the oxygen sensor to 20.9% volume. If the required adjustment is greater than +/- 0.5% volume, the unit will return to its previous calibration. If the oxygen sensor does not calibrate, a new sensor may be required. During the AutoCal[®] period, alarms will be de-activated for 15 seconds.

When oxygen levels of supplied air may not normally be 20.9% volume, or a 15 second alarm deactivation is a concern, the unit may be set to AutoCal[®] oxygen off.

Manual Calibration of Oxygen Sensor

To set the oxygen at 20.9% volume and carbon monoxide to zero, follow the instructions for “ZERO/CAL” adjustment for carbon monoxide below.

“ZERO/CAL” Adjustment for Carbon Monoxide

The carbon monoxide read-out (ppm) will be “0” in the absence of carbon monoxide. This “0” can be calibrated by flowing clean air over the sensor and activating the ZERO/CAL set switch.

The “ZERO/CAL” switch is activated through a small hole in the face of the unit using a bent paper clip or similar thin wire or tool.

Two methods are available to check or set the carbon monoxide ZERO/CAL.

With normal flow through the unit from a clean air supply depress the ZERO/CAL switch and hold until the carbon monoxide read-out stops flashing (about 3 seconds) and then immediately release the switch.

The auto zero process will begin immediately. If the supply air is clean the display will indicate **CO SET, END CALIBRATION** which indicates that a zero setting has been accepted and is now in use. If the supply line has more than a trace of carbon monoxide, the following messages will appear: **BAD O AIR, PREV CAL, END CAL**. The instrument is informing the user that it will not calibrate because of bad zero air and it will use its previously zeroed calibration setting.

The other method to zero the unit is to supply zero test gas (impurity free air) to the calibration port in the same manner as described above with calibration gas, and the unit will initiate its calibration gas routine. However, the unit expects that 20 ppm CO is being applied to the calibration port unless the zero switch is pushed. Check to see that the message says zero gas instead of calibration gas as the 60 second countdown proceeds. At any time during the countdown the zero switch may be pushed to calibrate the unit with zero gas. If the

switch is not pushed, a cal fail message will appear, resulting in a return to the previous calibration. After the zero switch is pressed, a **ZEROING** message appears and then **RELEASE UNLESS ZERO INIT** message.

Holding the zero switch for 15 seconds will reinitialize the unit. This step is used when replacing a sensor or as discussed in the troubleshooting section. Do not ZERO INIT unless instructed to do so in the troubleshooting section.

Maintenance (qualified technicians only)

NOTE: Except for the sensors, all internal parts are to be serviced only by the factory or its authorized agents.

Oxygen Sensor Replacement

The oxygen sensor output will eventually reach a low level where it will be unstable and calibration will not be possible. To replace the sensor, disconnect the power to the unit and remove the four corner screws and the electronics front cover. Next, remove the three screws that hold the sensor block and unplug the O₂ sensor from its socket. Replace with a new sensor. Reassemble the unit and reconnect it to the power source.

1. Push the top of the two set-up mode switches and the display will read **O2 XXX**.
2. Adjust the control pot to obtain a reading of **O2 200** (the control pot is located on the display board-this is the only control pot).

Push the bottom setup switch to return the instrument to normal display mode.

1. Let the new sensor settle in for an hour prior to calibrating.
2. Follow ZERO/CAL instructions to reset the sensor to 20.9% volume.

Carbon Monoxide Sensor Replacement

When CO test gas fails to show a gas response during calibration, a new sensor is required. Most CO sensors will last from one and a half years to three years.

To replace the sensor, disconnect the power to the unit and remove the four corner screws and the electronics front cover. Next remove the three screws that hold the sensor block and unplug the CO sensor from its socket. Install a new sensor after **being sure that the shorting wire is removed** from the new sensor. Reassemble the unit and reconnect it to power. Let the new sensor settle in for an hour before calibrating.

A NEW SENSOR MUST BE INITIALIZED

When calibrating a new sensor, an initializing step is added to the procedure. This permits the sensor to be zero calibrated regardless of the background air and caution must be taken that the air is free of carbon monoxide. If the supply line is not CO free, then obtain a tank of impurity free air test gas from GfG (stock number 7802-006).

To initialize the unit, hold the ZERO/CAL switch for 15 seconds (airline OFF). During the fifteen seconds, messages will read: **ZERO CAL, RELEASE UNLESS ZERO INT, INIT-ING**. Release the zero set switch when INIT-ING appears and the display will read: **ZERO GAS REQUIRED**.

Supply clean air from either the supply line or calibration port and the unit will set its ZERO/CAL after 60 seconds. The instrument message will then read **CAL GAS REQUIRED**.

Supply 20 ppm calibration gas (or another value selected in the setup mode on the unit) until the display reads **END CAL, REMOVE GAS, SUPPLY ON**. After turning the air supply on, the unit will reset the error protection and monitor the carbon monoxide of the compressor air supply line.

Troubleshooting

Count Numbers

Another set of numbers is displayed during CO calibration beside the gas concentration. These numbers are there to assist in troubleshooting in case zero or calibration fails or other malfunctions occur. These numbers are called counts.

The CO zero calibration will not set if the counts are less than 46 or greater than 53; when the unit sets to zero, the number will read 50 ± 1 counts. With 20 ppm CO calibration gas the count number will be 70 ± 1 to set. If the computer cannot auto adjust the readout to these values of 50 and 70, the zero or calibration will fail.

Zero Fail During CO Calibration

If a failure occurs during CO zero calibration, it means the counts are not between 46 and 53. If the counts are above 53, a **BAD AIR** message occurs and the zero air should be checked for CO content. When the count level is below 46, it may be a malfunctioning unit or during initial zero calibration (without the error protection), it could have been zeroed with a contaminated gas sample.

Another initialization will remove the 46 to 53 count restraint, and with known zero air the unit may be re-zeroed. If the counts never reach 0, the unit is malfunctioning; please call the factory for further instructions.

Calibration Gas Fail During CO Calibration

With 20 ppm CO gas supplied to the unit, the reading should reach 70 counts. If the reading does not reach 70 counts, use the appropriate procedure:

1. If the counts or gas reading do not show any increase when the gas is applied, the sensor is probably expired or the test gas has a concentration of zero CO. Check the hose connections to assure that gas is flowing into the sensor chamber.
2. If the counts are close to 70, a zero reinitializing with known zero gas will probably correct the problem. If the unit was initialized with more than 2 ppm of CO, the calibration will fail when 20 ppm test gas is applied.

CAUTION: Be sure that the cylinder in use is “zero gas” impurity free air (standard air) when zero initializing.

Accessories and Field Replacement Parts

Accessories

Calibration kit (includes calibration connector and 20 ppm test gas 34 L)	7750-001
High pressure regulator (5,000 PSI)	2605-002
Remote horn – 110 VAC	1301-002

Replacement Parts

CO sensor – chemical cell	5503-020
Oxygen sensor	5701-011
Regulator	2608-004

Test Gas

20 ppm carbon monoxide 34 L	7802-001
Impurity free air 34 L	7802-006

Equipment Technical Data

Gases Detected	Carbon Monoxide	Oxygen
Sensor	Electrochemical cell	Electrochemical cell
Meter scale	0-100 ppm CO	0-25% volume
Response	90% maximum in 20 seconds	95% in 15 seconds
Accuracy, expected	+/- 1 ppm	+/- 0.1% volume
sensor life	2-3 years	12-18 months
Sensor warranty	1 year	1 year
Operating temperature range (sample air)	+32 to 105°F	
Factory set adjustable alarm points	5 ppm CO and (H) 10 ppm CO	19.5% low 22.0% high
Standard inlet pressure	½" feed - 80 to 120 psig	
Sample flow rate	0.8 cubic feet of air per hour (scfh)	
Relays		
1 – CO alarm	250 VAC / 30 VDC @ 7 A	
1 – Oxygen		
Power source	110 VAC @ 1 A or 12 VDC	
Dimensions	4x5.9x7.3 inches (HxWxD) (101x150x185 mm)	

Warranty

GfG Instrumentation warrants our products to be free from defects in material and workmanship when used for their intended purpose, and agrees to remedy any such defect or to furnish a new part (at the option of GfG Instrumentation) in exchange for any part of any product that we manufacture that under normal use is found to be defective; provided that the product is returned, by the purchaser, to GfG's factory, intact, for our examination, with all transportation costs prepaid, and provided that such examination reveals, in our judgment, that it is defective.

This warranty does not extend to any products that have been subjected to misuse, neglect, accident, or unauthorized modifications; nor does it extend to products used contrary to the instructions furnished by us or to products that have been repaired or altered outside of our factory. No agent or reseller of GfG Instrumentation may alter the above statements.

New Style

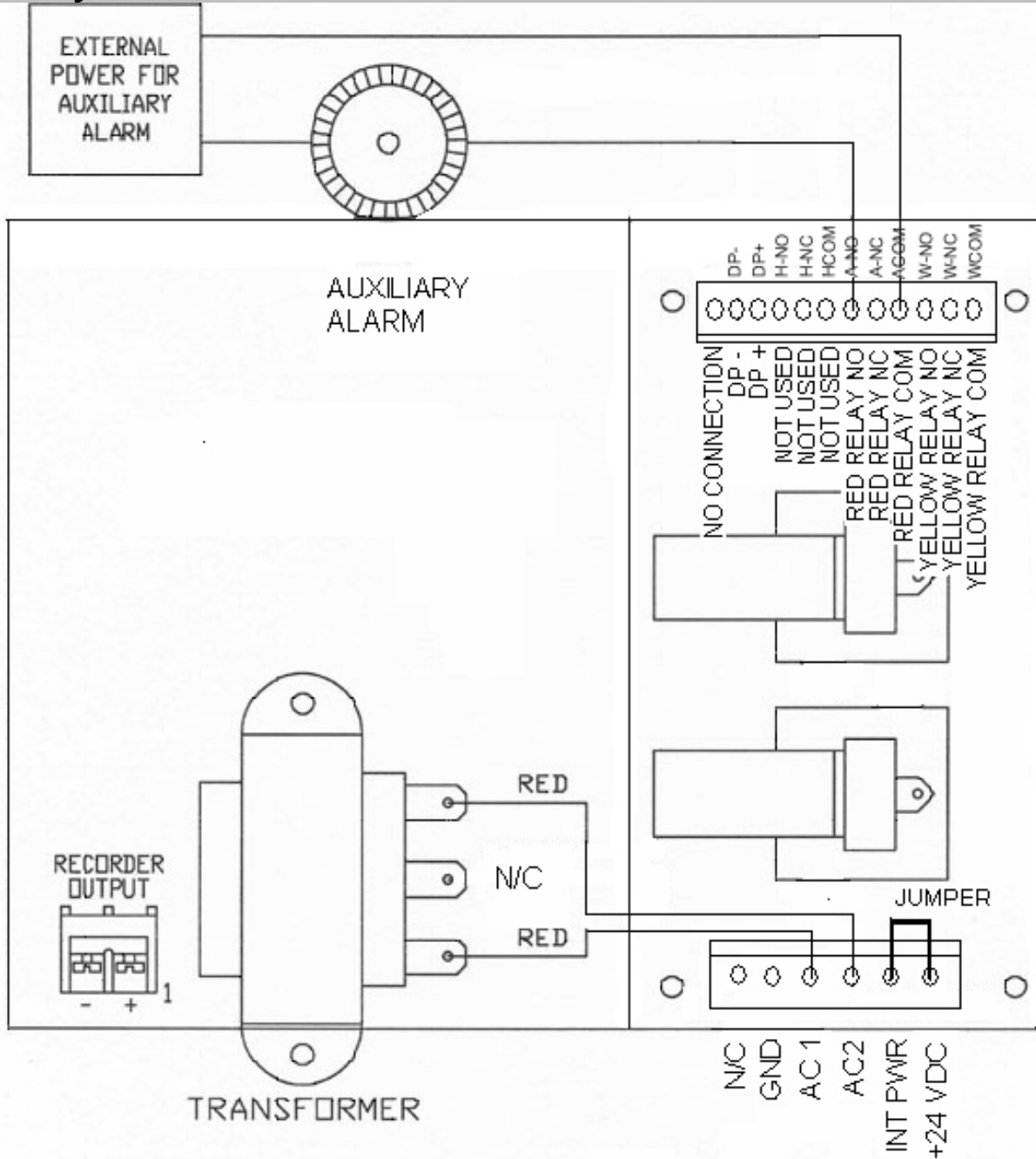

NOTE: Optional GfG remote horn part number 1301-002

Old Style

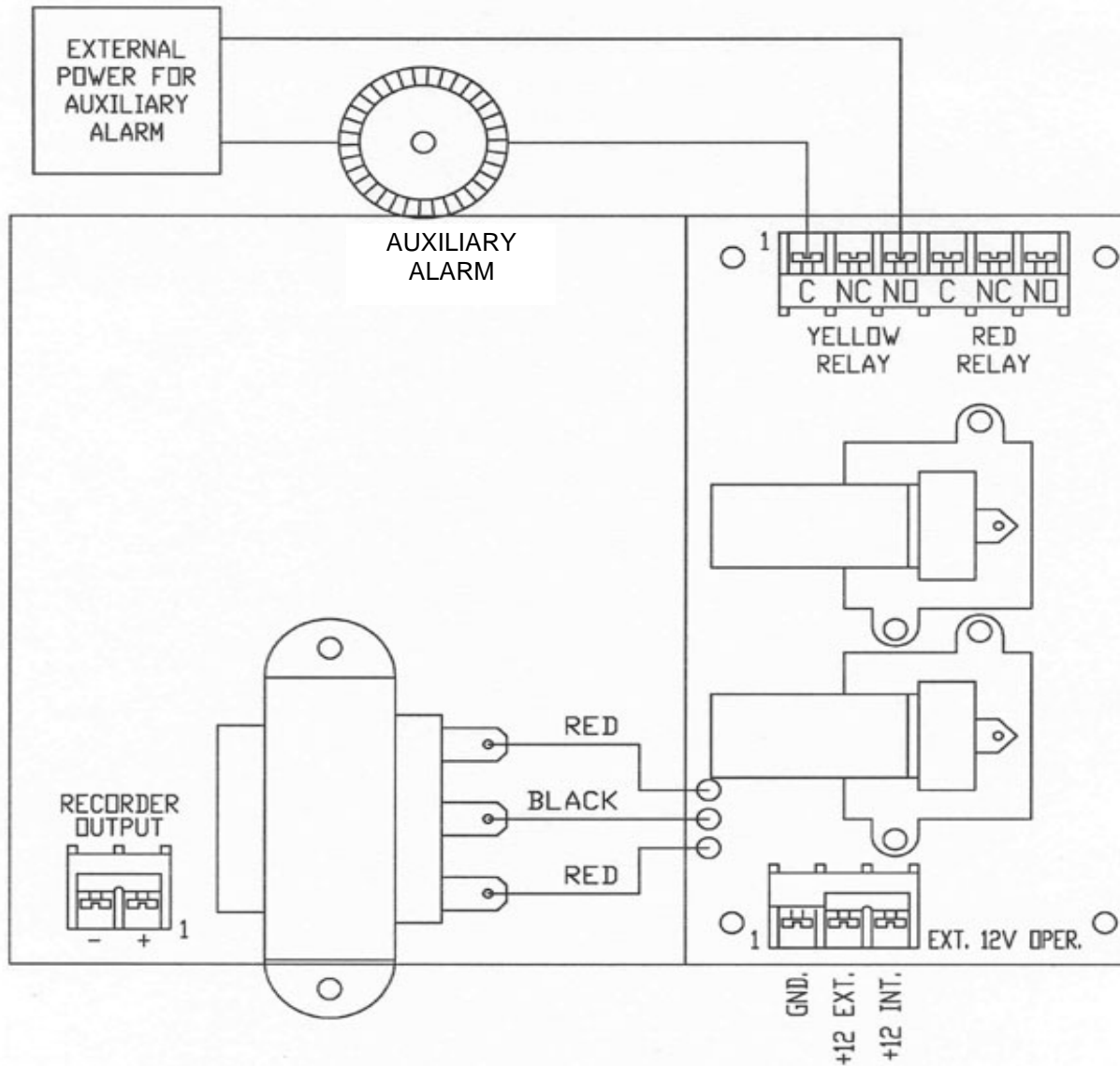

TRANSFORMER

1702-113B
POWER BOARD

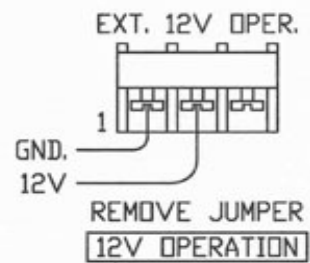



GfG Instrumentation

1194 Oak Valley Drive, Suite 20
Ann Arbor, Michigan 48108 USA

Phone: (800) 959-0329 or (734) 769-0573

Fax: (734) 769-1888

E-mail: info@gfg-inc.com

Web: www.gfg-inc.com