

RAM 744

Operation Manual



GfG Instrumentation

Worldwide Manufacturer of Gas Detection Solutions

Table of Contents

	Page
For Your Safety	3
Application.....	3
General Description	3
Detection Principle	4
Operation	4
Design	4
Turning the Device ON.....	5
Turning the Device OFF	5
Function Modes.....	5
LEDs	6
Power Supply	6
Calibration	7
Zero Point Adjustment.....	7
Alarm Set Point	8
Sensor Replacement.....	8
Troubleshooting	9
Technical Data	10
Replacement Parts and Accessories	11
Auxiliary Horn Wiring Diagram	11
Warranty.....	12

For Your Safety

Like any piece of complex equipment, the GfG RAM 744 will do the job it is designed to do only if it is used and serviced in accordance with the manufacturer's instructions. All individuals who have or will have the responsibility of servicing the equipment must carefully read this manual.

The warranties made by GfG Instrumentation with regard to this instrument are voided if the product is not used and serviced in accordance with the instructions in this manual. Please protect yourself and others who depend on this instrument by following these instructions. The above does not alter statements regarding GfG Instrumentation's warranties and conditions of sale and delivery.

Application

The RAM 744 is an inline respiratory air monitor for protection from carbon monoxide in compressor supplied breathing air. This instrument should be used to continuously monitor compressor supplied breathing air. Random sampling only checks the air at that moment. It is possible for any air compressor to draw carbon monoxide through its air intake at any time. The RAM 744 will provide both visual and audible alarms if carbon monoxide levels exceed the preset alarm level. An auxiliary relay allows for connection to a remote device.

The RAM 744 has been designed for use both indoors and out and will withstand water splashes or droplets. However, it is not waterproof and should not be subjected to direct spray or immersion.

General Description

The RAM 744 is a compact monitor designed for use in portable and stationary applications. It is designed to be installed inline by a 1/2" NPT inlet and outlet fitting and should only be used in conjunction with an acceptable filter panel that contains a coalescing/carbon filter.

The RAM 744 is easily operated with one button and a rotary cam valve switch. All user functions can be done with these two switches.

Detection Principle

The RAM 744 measures carbon monoxide using an electrochemical sensor. The electrochemical sensor consists of an electrolyte, a working electrode (anode) and a counter electrode (cathode). The ability to select specific electrodes and electrolytes makes the sensor suitable for any applicable gas. The gas passed between the electrolyte and the electrode generates an electrical signal that is proportional to the gas concentration. GfG electrochemical sensors utilize capillary diffusion barrier technology.

Operation

The RAM 744 is designed to be plumbed inline with the compressed air. The monitor does not affect PSI or SCFM. A small amount of air (~0.5 lpm) is diverted through a preset internal regulator and flow restrictor, delivering a continuous flow of sample air to the sensor chamber. A low flow alarm will indicate a lack of or an inadequate supply of air to the sensor. A removable plate protects the on/off switch, battery chamber and alarm relay contacts. The instrument can be powered by a 9 V battery or an optional 12 VAC/DC adapter.

Design

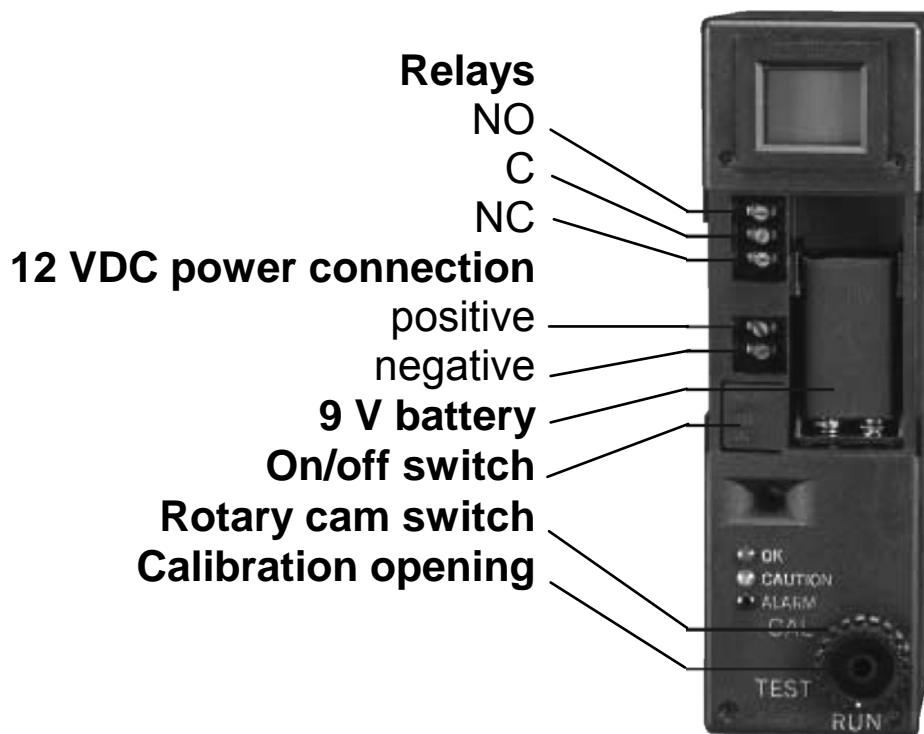

Turning the Device ON

The on/off switch is located behind the cover panel. The cover panel can be easily removed by lifting it from either side. To turn the instrument on, press and release the on/off button. “Hello” will scroll through the display, and the instrument will then proceed with a 60 second warm-up count down.

Turning the Device OFF

Press the on/off button for three seconds; the instrument will beep twice and then sound a series of short beeps as the unit turns off.

Function Modes

The rotary cam switch sets the functions for the RAM 744 and can be switched between RUN, TEST, and CAL.

RUN mode is the operation/detection mode. The RAM 744 must be in RUN mode to monitor the supplied breathing air. Supplied air must be turned on and flowing to the instrument while the device is in this mode. If the supplied air is turned off while the instrument is in RUN mode, the low flow alarm will sound until the supplied air is turned on.

TEST mode allows bump testing of the sensor or silencing of the low flow alarm when the supplied air is shut off. To bump test the instrument, place the instrument in TEST mode and flow the calibration gas into the opening on the cam valve. In test mode, the supplied air will not be monitored. There is no need to turn the supplied air off when entering this mode.

CAL mode is for calibration and zero calibration. When the RAM 744 is switched to CAL mode, the supplied air will not flow to the sensor (there is no need to shut off the supplied air). When in CAL mode, AC (AutoCal[®]) will be displayed. Pressing the on/off button while in this mode will change the display to A0 (auto zero). For calibration and zeroing instruction, see *Calibration*.

F1 (fault) is displayed when the cam valve is not positioned in one of the three modes.

LEDs

A green LED (OK) in run mode indicates a safe condition.

A yellow LED (caution) indicates that the instrument is out of RUN mode and is not monitoring the supplied air or that the instrument is in run mode but the battery is low (LB).

A red LED (alarm) indicates that the alarm threshold has been exceeded or that there is no air flow to the sensor. If the alarm threshold is exceeded, the CO value will be indicated on the display. If the low flow alarm is sounding, LF will be displayed.

Power Supply

The RAM 744 may be powered by a 9 V alkaline battery or with an optional external 12 V power supply applied to the 12 V terminal block.

9 V Battery Installation and Replacement

The 9 V battery is installed under the panel cover. To remove the panel cover, lift it off from either the left or right side. The RAM 744 will indicate a low battery (LB) if the battery is too low.

12 V External Power

When an optional 12 V power supply is connected to the 12 V terminal block, the instrument will use this power supply as its primary source. The 9 V battery may be installed and will serve as a backup power supply only (see *Design*).

Calibration

The RAM 744 is an AutoCal[®] instrument. All calibration adjustments are made by the microprocessor.

1. To initiate a calibration, rotate the cam valve switch to the CAL position. AC will appear on the display.
2. Insert the calibration connector into the opening in the cam valve.
3. Attach the calibration valve to the calibration gas cylinder (10 ppm CO).
4. Open the cylinder valve fully (the flow rate is preset and there is no need to adjust it).
5. The red LED will continue to blink for 90 seconds.
6. Watch for the green LED to blink, as this indicates a successful calibration.
7. Remove the calibration gas and rotate the cam valve to the RUN position.

Zero Point Adjustment

Zeroing (zero calibration) should be performed when the zero point has drifted. GfG Instrumentation recommends using impurity free test gas to zero this sensor, but the sensor can be zeroed without it.

1. To initiate a zero calibration, rotate the cam valve switch to the CAL position. AC will appear on the display.
2. Press the on/off button until it beeps.
3. A0 will now appear on the display.
4. The red LED will continue to blink for 90 seconds.

Follow steps 5-7 if you are using impurity free test gas:

5. Insert the calibration connector into the opening in the cam valve.
6. Attach the calibration valve to the impurity free air gas cylinder.
7. Open the cylinder valve fully (the flow rate is preset and there is no need to adjust it).
8. Watch for the green LED to begin blinking. This indicates a successful zero.
9. Remove gas (if applied) and rotate valve to RUN.

Alarm Set Point

The RAM 744 is shipped with a factory preset alarm level of 10 ppm CO.

Sensor Replacement

The sensor is located on the PCB and is easily accessible by removing the front of the housing from the RAM 744.

To gain access to the PCB, remove the four screws on the front of the RAM 744. After removing the four screws, gently pry the front of the housing off, starting at the bottom of the instrument.

WARNING: Removing the front of the housing by prying at it from the top will result in damage to the housing. This damage is not covered by the warranty.

1. Gently pull out the old sensor.
2. Remove the shorting clip from the new sensor.
3. Align the pins and gently push the new sensor into the sockets.

After replacing the sensor, allow the instrument to warm up for at least 30 minutes. The new sensor must be zeroed and calibrated (see *Calibration and Zero Point Adjustment*).

Troubleshooting

Failure	Solution
Instrument will not calibrate	<ul style="list-style-type: none"> • Perform a zero calibration, using impurity free air. If the instrument zeroes, perform a calibration using 10 ppm CO. • Verify that the calibration gas is 10 ppm CO and verify that the gas cylinder is not empty. • If the instrument will not calibrate after trying the above, replace the sensor (See <i>Sensor Replacement</i>).
Instrument will not zero	<ul style="list-style-type: none"> • If the instrument does not zero if you follow the zeroing instructions with impurity free gas, replace the sensor.
Instrument has a (-0) reading or displays other than a (0) reading	<ul style="list-style-type: none"> • Re-zero the instrument (follow the zero instructions with impurity free gas).
Instrument zeros during zero calibration and the reading increases after returning to RUN mode	<ul style="list-style-type: none"> • The supply air is contaminated. Check air source.
Instrument will not turn on	<ul style="list-style-type: none"> • Check power supply. Verify that the battery is good. If the power supply is good and the instrument will not power up, return it to the factory for service.

If the above solutions do not solve the problem or a problem other than those listed above exists, contact GfG Instrumentation.

The technical support staff will offer additional solutions or advise you to return the instrument to the factory. All instruments returned to GfG must be accompanied by a "Repair Return Form," which can be obtained by contacting the factory at (800) 959-0329 or (734) 769-0573.

Technical Data

Gases	Carbon monoxide (CO)
Detection range	0-99 ppm
Detection principle	Electrochemical cell
Display	2 digit 0.5" backlit* LCD *External power sources only
Alarm point	10 ppm
Alarms	Audible 83 dB at 1' (30 cm) Visual Flashing LED External alarm 90 dB at 1 m
Airline inlet / outlet	Standard pressure 70 to 150 psi ½" FPT – 50 to 100 CFM panels (wall mount) ⅜" – 25 CFM panels (wall mount) Dynaquip quick connects – outlet
Available relay contacts and ratings	N/O, common, N/C 0.3 A at 125 VAC 0.1 A at 30 VDC
Sample flow rate	1.0 cubic feet of air per hour (scfh)
Power source	110 VAC (wall pack) 12 VDC external 9 VDC internal
Temperature range	-4 to +122°F / -20 to +50°C
Expected operating life	3 years
T₉₀ response time	<35 seconds
Relative humidity range	15 to 90% non-condensing

Replacement Parts and Accessories

Description	Part Number
Adapter, power 110 VAC (optional power supply)	4001-027A
Adapter, calibration	7740-744
Calibration connector (with tubing and gas valve)	7701-744
Carbon monoxide (CO) 10 ppm / air / steel / 34 L	7802-013
Zero gas (impurity free air) / steel / 34 L	7802-006
Calibration kit (Includes fixed flow regulator, calibration adapter, tubing, test gas cylinder and carrying case)	7735-101
Carbon monoxide (CO) sensor	5704-017
Regulator - on / off (1.0 lpm)	7750-004
Filter kit (for 8025)	2609-25P
Filter kit (for 8050)	2609-50P
Filter kit (for 8100)	2609-100P
Horn, remote 110 VAC	1301-002
Horn, remote 12 VDC	1301-001
Horn, remote with 25 feet of cable (portable units only)	1301-744

Auxiliary Horn Wiring Diagram

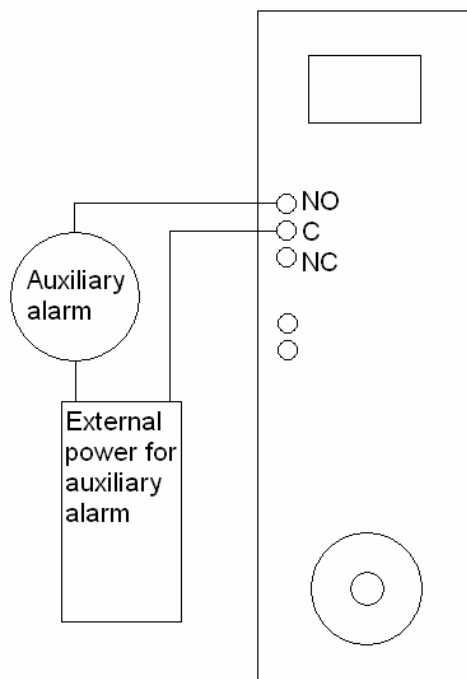

Warranty

GfG Instrumentation warrants our products to be free from defects in material and workmanship when used for their intended purpose, and agrees to remedy any such defect or to furnish a new part (at the option of GfG Instrumentation) in exchange for any part of any product that we manufacture that under normal use is found to be defective; provided that the product is returned, by the purchaser, to GfG's factory, intact, for our examination, with all transportation costs prepaid, and provided that such examination reveals, in our judgment, that it is defective.

This warranty does not extend to any products that have been subjected to misuse, neglect, accident, or unauthorized modifications; nor does it extend to products used contrary to the instructions furnished by us or to products that have been repaired or altered outside of our factory. No agent or reseller of GfG Instrumentation may alter the above statements.



GfG Instrumentation

1194 Oak Valley Drive, Suite 20
Ann Arbor, Michigan 48108 USA

Phone: (800) 959-0329 or (734) 769-0573

Fax: (734) 769-1888

E-mail: info@gfg-inc.com

Web: www.gfg-inc.com